

PS-4100 Series CO POTS Splitter Shelf

Installation Quick Step



PS-4101 Front View



PS-4101 Rear View

Planning Shelf Installation

The PS-4101 shelf requires 1.75" of rack space.

The PS-4102 shelf requires 3.50" of rack space.

The PS-4103 shelf requires 5.25" of rack space.

All shelves are installed with the mounting bracket on the front of the rack mounting rails (center mount). Shelves can be mounted in a 19" rack by installing the mounting brackets with the long end on the splitter shelf, or a 23" rack by installing the mounting brackets with the short end on the splitter shelf. By rotating the mounting brackets, the shelf can be installed with connectors front or rear facing.

Installing the Ground Wire

To comply with the Network Equipment Building Systems (NEBS) requirements, a suitable ground wire must be installed. The grounding point is located on the lower left side of the shelf, and marked with a UL safety ground symbol. This connection is designed for a # 10/32 screw which is supplied with the shelf.

Installing the POTS Splitter Card(s) in the Shelf

Insert the Splitter cards into the shelf card guides with *components facing up*. Care should be taken to insert cards into the correct left side and right side card guides. Make certain the cards are not misaligned which would prevent the cards from seating properly into their connectors when using the locking / ejector tab.

Note 1:

The PS-4100 series shelves will accept PS-4100, PS-6800 and PS-6900 series splitter cards. Please see the applicable data sheets for application information.

Cabling Overview

The POTS Splitter Shelf should be located as close as practical to the DSLAM equipment. The physical cable interface is a standard 50-position RJ-21 AMP-type *female* shielded connector. Each POTS Splitter card uses only 24 pairs of the 25 pairs on each connector. (see connector pinout chart)

Cable Routing

On the rear of the shelf, the **DSL**, **LOOP** and **PSTN** interface connectors, are oriented with PIN 1 to the left, so a standard 90° cable connector will dress to the left; this is appropriate for the DSL connector only. A 110° or 180° connector is recommended for the LOOP and PSTN interfaces to avoid cable interference. If a 90° connector is used, it should be secured with the single connector screw, and a plastic cable tie to the anchor point on the shelf.

Note 2:

A minimum of 26 AWG wire is required for UL compliance.

Note 3:

The #4-40 screw(s) supplied with the cable connectors may be too long to connect to the jack-hex screws on the shelf as shown in **Figure 1**. Extend the screw fully. If it is flush with, or goes past the connector's body as shown in **Figure 2** point (B) the screw is too long. Replace the screw so when fully extended the end of the screw is about 1/16 inch (1.5mm) from the bottom of the connector's body as shown in **Figure 2** point (A).

Note 3:

Each shielded connector on the rear of the shelf is grounded via the jack / hex connector screws. For continued ground continuity, do not remove the jack / hex connector screws.

Note 4:

For video applications, CAT-5 25-pair 24 AWG cable with CAT-5 rated connectors such as AVAYA 525 are recommended for the DSL & LOOP ports.

CAUTION

When mounting this equipment in relay racks, care should be taken such that a hazardous condition is not achieved due to uneven loading. Follow your company's policies and procedures when mounting equipment in relay racks.

All POTS splitter equipment must be installed on loops with primary surge protection.

Connector Pinout

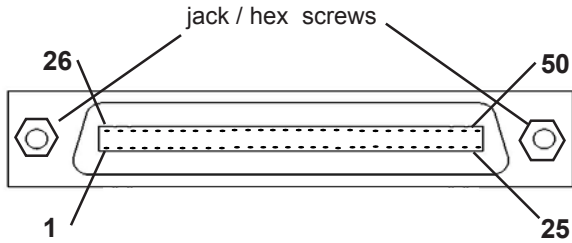

Figure 1: Rear panel female connector

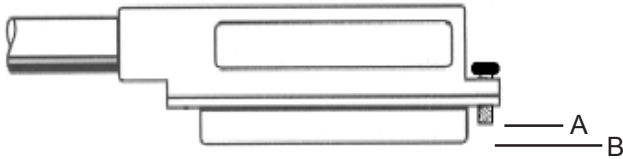

Figure 2: Male cable connector

DSL, LOOP & PSTN Connector Wiring

Filter #	Pin # Ring	Pin # Tip
1	1	26
2	2	27
3	3	28
4	4	29
5	5	30
6	6	31
7	7	32
8	8	33
9	9	34
10	10	35
11	11	36
12	12	37
13	13	38
14	14	39
15	15	40
16	16	41
17	17	42
18	18	43
19	19	44
20	20	45
21	21	46
22	22	47
23	23	48
24	24	49
N/C	25	50

Technical Specifications

Item	Specification
PS-4101	(Height x Width x Depth) 1.75" x 16" x 10.44" (4.44cm x 40.64cm x 26.52cm)
PS-4102	3.50" x 16" x 10.44" (8.89cm x 40.64cm x 26.52cm)
PS-4103	5.25" x 16" x 10.44" (13.32cm x 40.64cm x 26.52cm)
Weight PS-4101 PS-4102 PS-4103	6.5 lbs (2.9 kg) 8.2 lbs (3.7 kg) 10.4 lbs (4.7 kg)
Rack Mounting	Supplied with rack adapters for 19" or 23" racks
Physical Interface	Three 50-pin AMP RJ-21type female connectors assigned to each POTS Splitter card for DSL, PSTN, and LOOP connections.
Environmental Operating Storage	-40°C to +70°C -40°C to +70°C
Power	The POTS splitter employs a passive design and requires no power to the shelf.

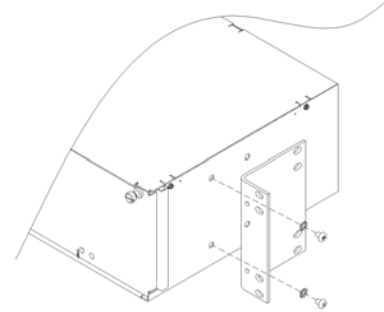

Figure 3: Mounting 19" rack adapters

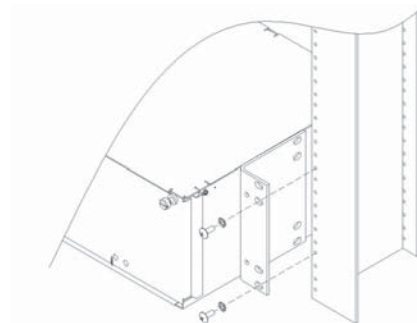

Figure 4: Rack mounting

Note 5:

Use # 10/32 screws and star washers supplied for mounting rack adapters to the shelf as shown in Figure #3 above and tighten screws to secure adapters to the shelf.

Note 6:

Use # 10/32 screws and star washers supplied for mounting the shelf in the rack as shown in Figure #4 above and tighten screws to secure shelf in the rack